

Detail Valve Box Installation

Note: Valve box shall not transmit shock or stress to the valve

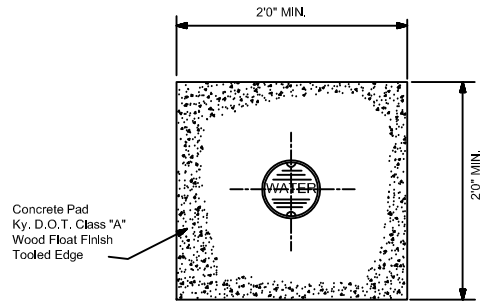

PLAN

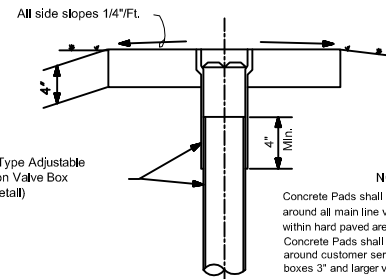

ELEVATION

NOTES
 Concrete Pads shall be constructed around all main line valve boxes except within hard paved areas.
 Concrete Pads shall be constructed around customer service line valve boxes 3" and larger valves.

REVISION	BY	DATE
1	MPS	6/29/09
2	MPS	9/22/09

N. KY. WATER DISTRICT VALVE BOX AND VALVE PAD DETAIL	DRAWN BY: SAR
	APPROVED: 
	DATE: 2/17/10
	STANDARD DRAWING NO: 105